





**INSTALLATION
INSTRUCTIONS**

PART NUMBER: F541SFJ000

DESCRIPTION: MOONROOF AIR DEFLECTOR

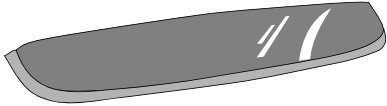
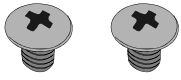
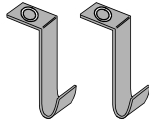
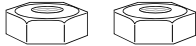
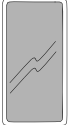
VEHICLE DESCRIPTION: SUBARU IMPREZA

<p>A</p> 	<p>B</p>  <p>1x 2x</p>	<p>C</p>  <p>2x</p>	<p>D</p>  <p>2x</p>
<p>E</p>  <p>2x</p>	<p>F</p>  <p>1x</p>	<p>G</p>  <p>2x</p>	

Tools Required

Phillips head screwdriver

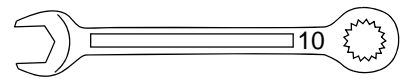
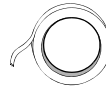
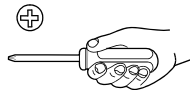

Meaning of Characters:



:Remove

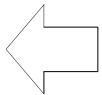

:Install



:Disconnect

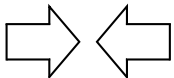

:Connect

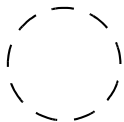

:Location of Clips or Screws

T

:Tightening Torque



:Loosen

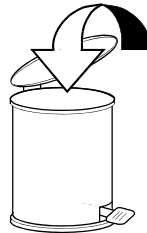

:Discard

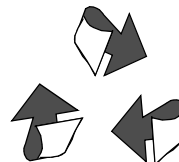

:Re - use

IMPORTANT NOTES

- DO NOT USE SOLVENT BASED CLEANERS ON MOONROOF AIR DEFLECTOR.
- DO NOT USE LOCTITE ON DEFLECTOR ATTACHING SCREWS.
- USE SOAP AND WATER ONLY TO CLEAN MOONROOF AIR DEFLECTOR.

The moonroof air deflector is designed to reduce wind noise when the moonroof is in the opened position. However, in some cases wind noise may be slightly louder with the moonroof in the tilt or closed position.

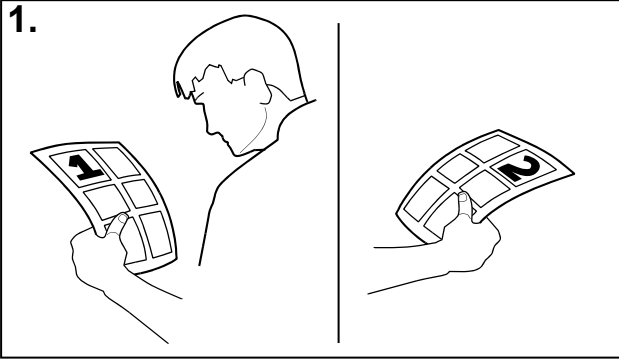

1.

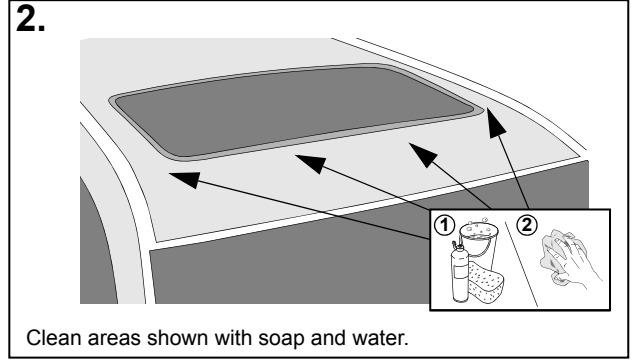

2.

Clean areas shown with soap and water.

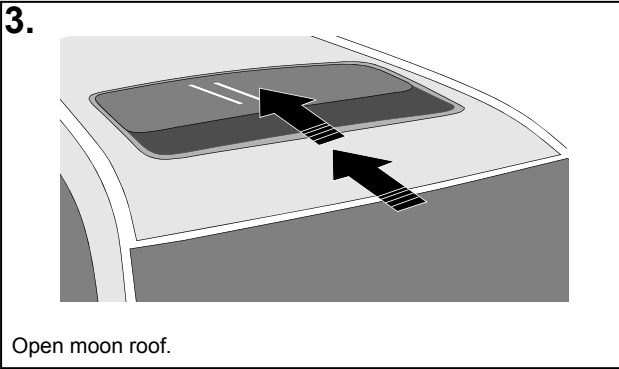

3.

Open moon roof.

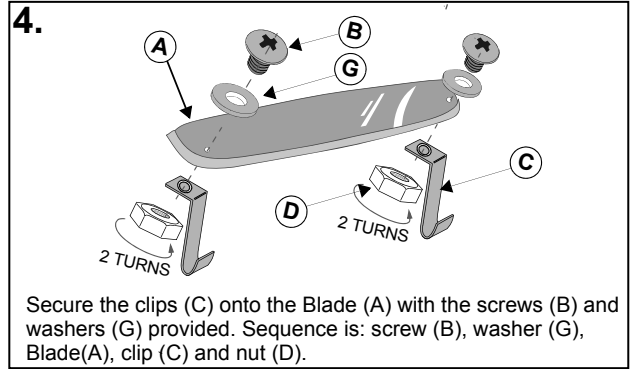

4.

Secure the clips (C) onto the Blade (A) with the screws (B) and washers (G) provided. Sequence is: screw (B), washer (G), Blade(A), clip (C) and nut (D).

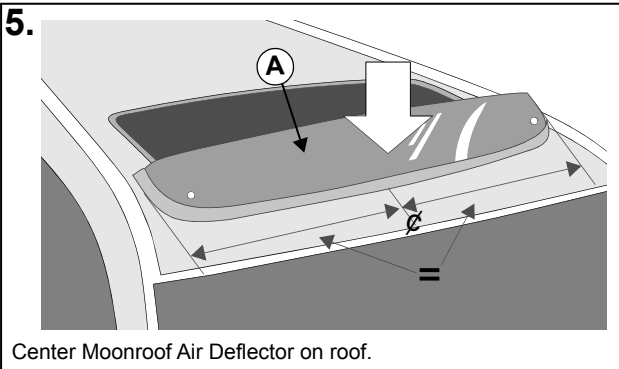

5.

Center Moonroof Air Deflector on roof.

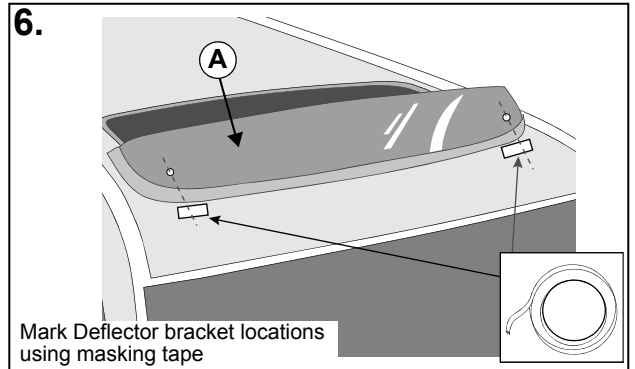

6.

Mark Deflector bracket locations using masking tape

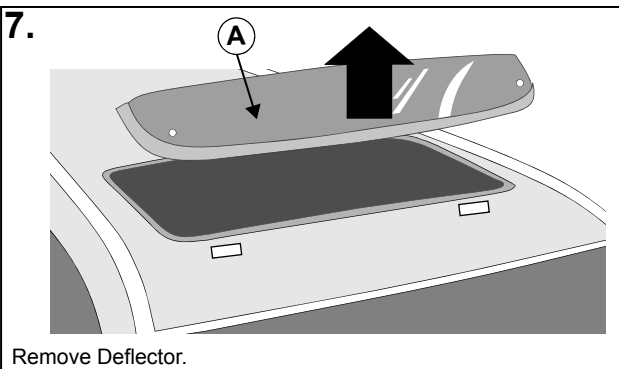

7.

Remove Deflector.

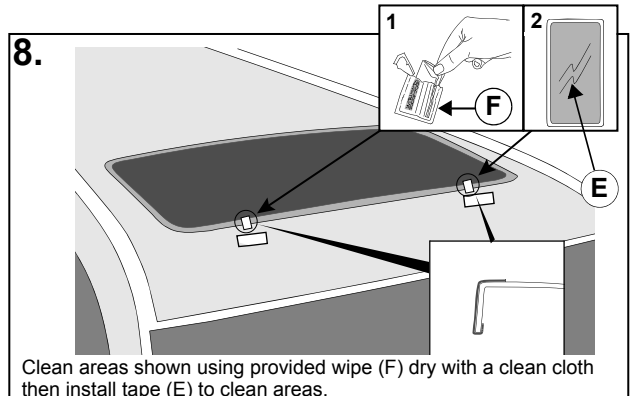

8.

Clean areas shown using provided wipe (F) dry with a clean cloth then install tape (E) to clean areas.

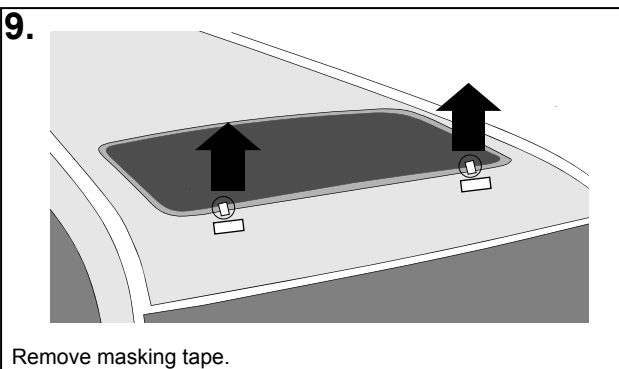

9.

Remove masking tape.

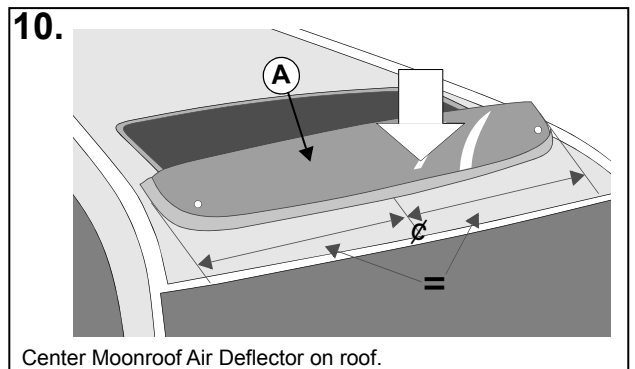

10.

Center Moonroof Air Deflector on roof.

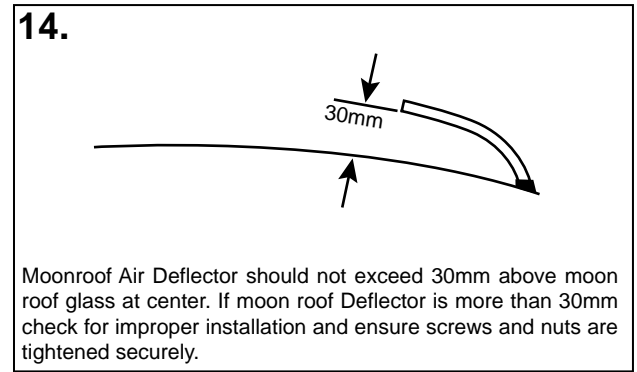
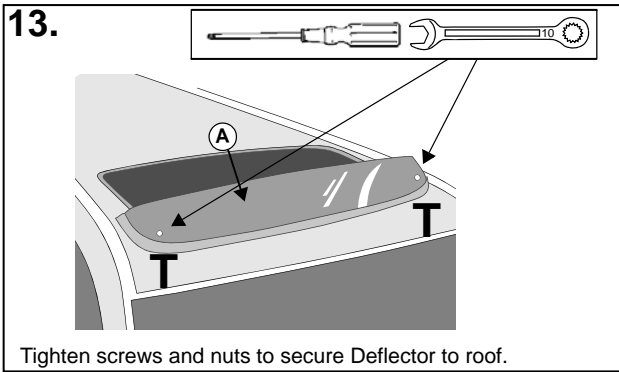
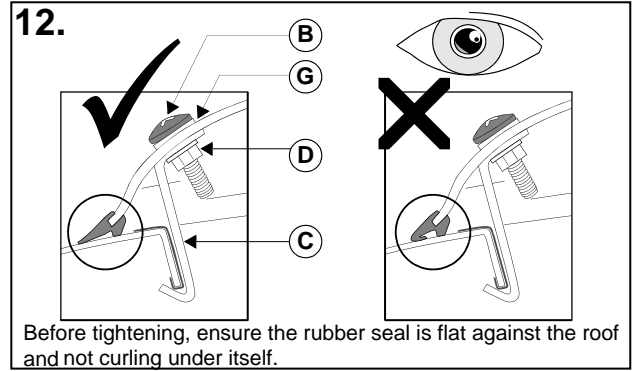
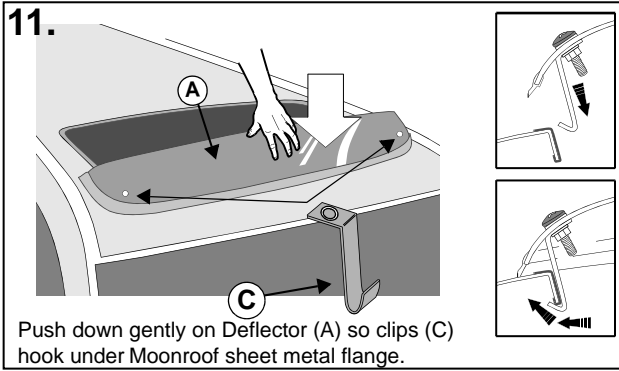

DO NOT USE solvent based cleaners on Moonroof Air Deflector.
USE soap and water only to clean Moonroof Air Deflector.

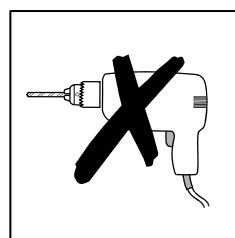









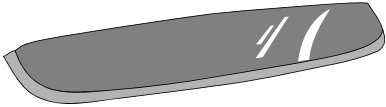

INSTRUCTIONS
D'INSTALLATION

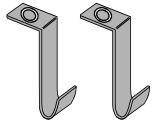
NUMÉRO DE PIÈCE : F541SFJ000

NUMÉRO DE PIÈCE : DÉFLECTEUR D'AIR DE TOIT
OUVRANT

VEHICLE DESCRIPTION: SUBARU IMPREZA

A  1x	B  1x	 2x	C  2x	D  2x	 2x
E  2x	F  1x	G  2x			

Outils requis

Tournevis Phillips



AUCUNE OUTIL ÉLECTRIQUE

Signification des symboles :



:Enlever

T

:Couple de serrage

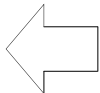

:Poser



:Desserrer



:Déconnecter

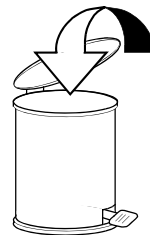

:Jeter

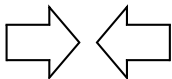

:Connecter

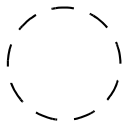

:Emplacement de fixation ou vis

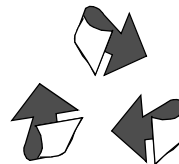

:Réutiliser

REMARQUES IMPORTANTES

- N'UTILISEZ PAS DE NETTOYANT À SOLVANT SUR LE DÉFLECTEUR D'AIR DU TOIT OUVRANT.
- N'UTILISEZ PAS DE FREIN FILETS (LOCTITE) SUR LES VIS DU DÉFLECTEUR D'AIR.
- UTILISEZ UNIQUEMENT DU SAVON ET DE L'EAU POUR NETTOYER LE DÉFLECTEUR D'AIR.

Le déflecteur d'air est conçu pour réduire le bruit de vent quand le toit ouvrant est en position ouverte. Toutefois, dans certains cas, le bruit peut être un peu plus fort si le toit est ouvert en inclinaison ou s'il est fermé.

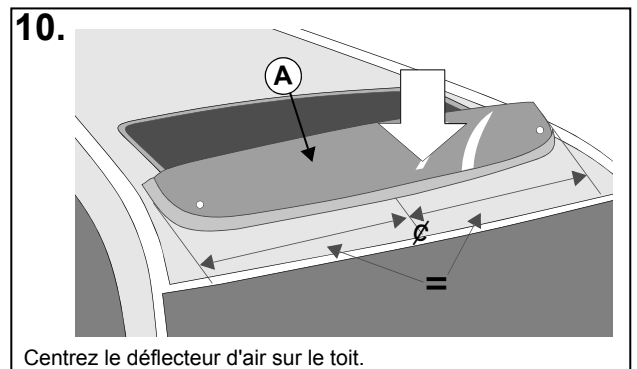
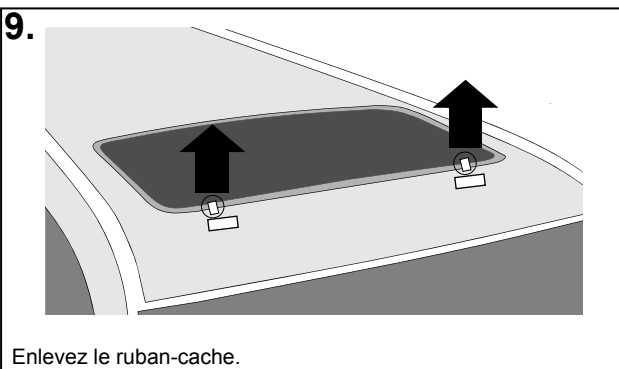
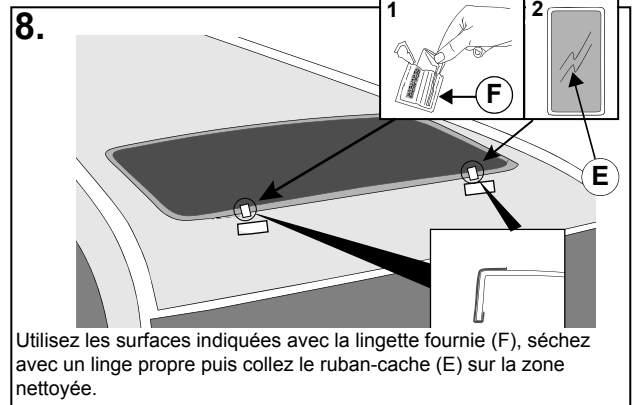
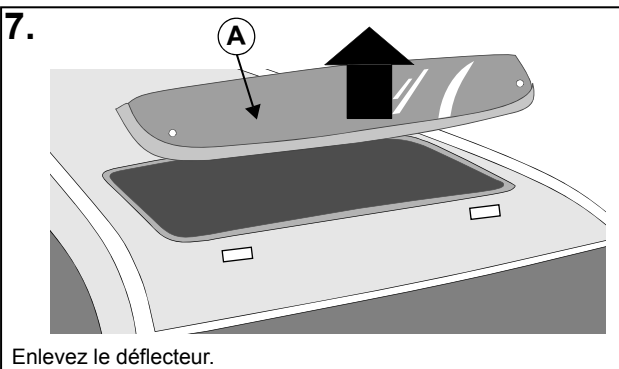
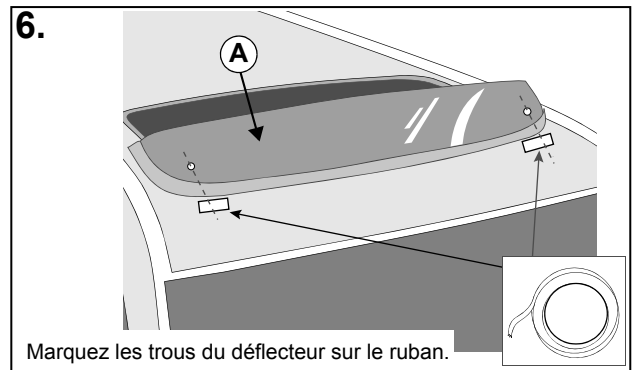
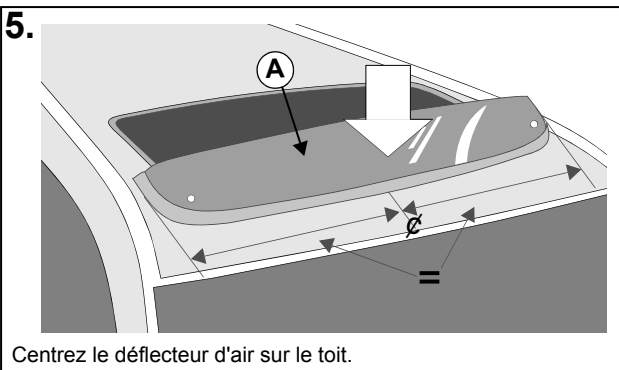
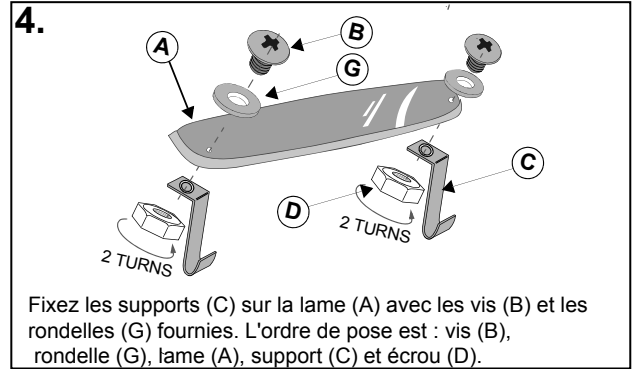
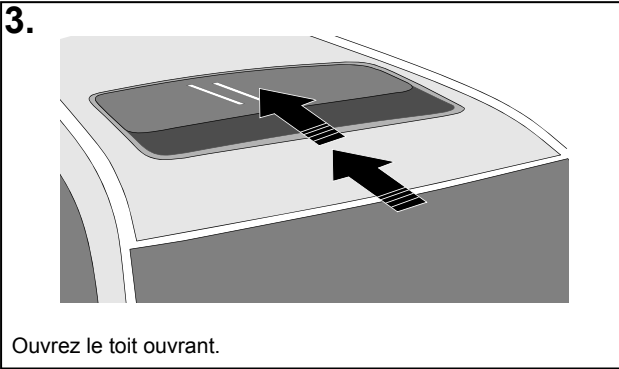
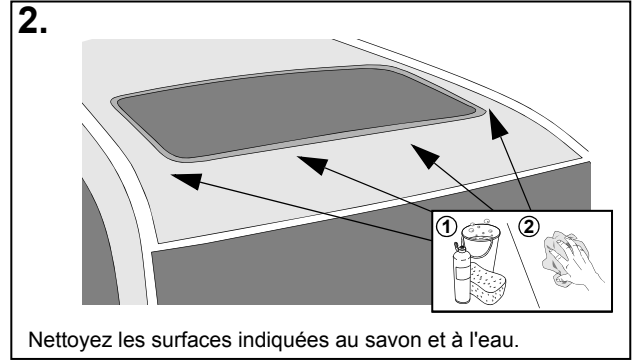
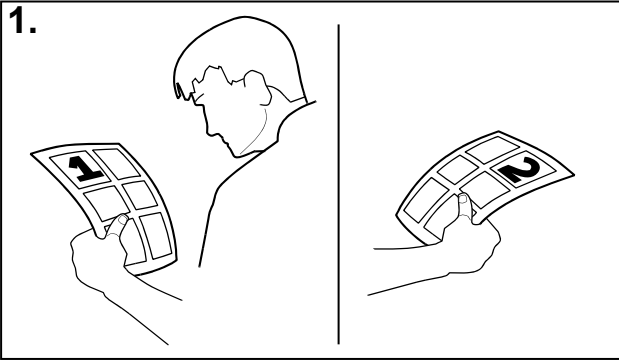

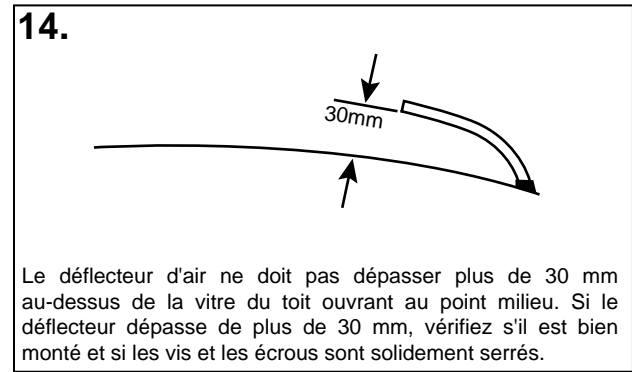
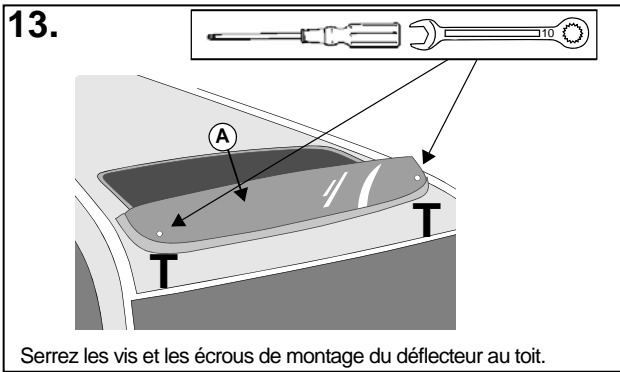
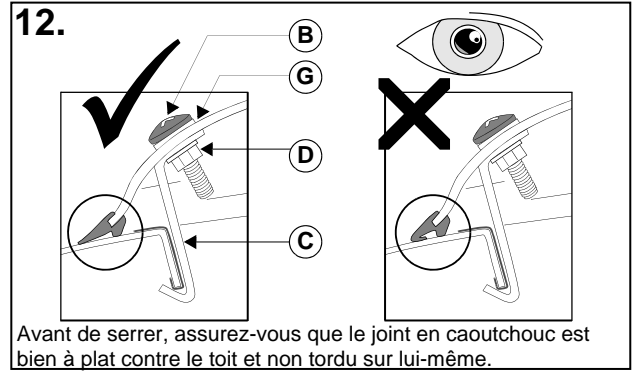
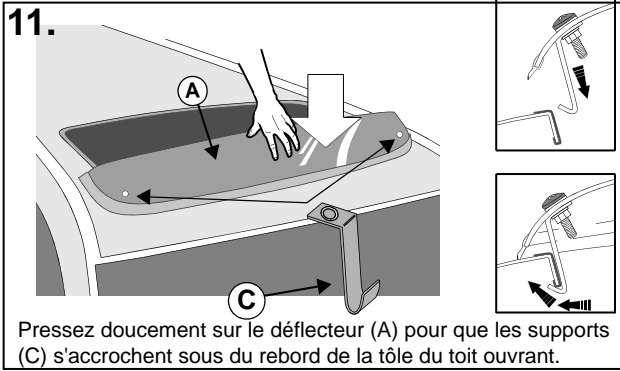

!
N'UTILISEZ PAS de nettoyant à solvant sur le déflecteur d'air du toit ouvrant.
UTILISEZ uniquement du savon et de l'eau pour nettoyer le déflecteur d'air.

